



Outdoor Musical Instruments
For Everyone, Everywhere



Natural Harmony™

Request a copy of the NEW evidence-based resource, **Natural Harmony™** An Instrumental Guide to Blending Music & Community, and share your stories at freenotesharmony.com

An Instrumental Guide to Blending Music & Community

Natural Harmony provides valuable tools to help create meaningful outdoor music spaces, as well as case studies that share examples of communities that have successfully used outdoor musical instruments to unite the community.

BENEFITS OF MUSIC ON COMMUNITIES

The Value of Amateur Music Making in the Community

For people who love music and enjoy performing for a live audience in their spare time, there are many positive benefits. Amateur musicians find the hours of performance rehearsals with others and the solitary practicing of musical selections to be leisure-time activities—an enjoyable, artistic experience with intrinsic value. Even though their rehearsals may be rigorous as they work on technical accuracy and perfect the quality of sound and intonation of feeling through the music, it is not viewed as work.¹¹

The depth of musical talent found in a community goes to the fabric of life for those living there. Highly skilled amateur musicians seek ways to share their musical passion with others, such as performing on the stage, in the orchestra pit for summer musical theatre productions, entertaining audiences in coffeehouses, performing on their corners on an outdoor band shell, or singing in cafeterias. These venues are vehicles for different music genres. Many communities have vibrant music scenes and, possibly, distinctive musical styles. Depending on the attributes of communities, listeners can enjoy diverse musical works. Music genres differ in tonal harmonies, texture, rhythmic patterns, and delivery. The list of music genres

is extensive; musical styles range in popularity from rock to hip-hop to country to Latin, and so on. Other categories cover bagpipes, blues, jazz, pop, classical, choral, and gospel music. The uplifting musical experiences that are shared through the blending of vocal or instrumental “voices” create bonds with listening audiences and boost community pride.

The Impact of Ensemble Musical Experiences

Singing with others, playing instruments in a group—the richness of shared musical experiences often creates new friendships to form. One study found that singing together in choir might have an “ice breaker” effect on participants, providing a faster path to new social connections than in other social situations.¹² Special bonds that form as singers blend their voices with others to create beautiful music can be very uplifting. Likewise, the hidden benefits become evident as singers learn friendships with others whose backgrounds and life experiences are very different.

From well-supported research findings, scientists know that the brain is altered in holistic, positive ways when musicians—amateurs and professionals—actively participate in making music. The musical

avenue for those who play instruments is actually quite broad. Musicians from preteens to senior adults can be involved in vibrant groups. Depending on their age, technical skill levels, and musical preferences, the groups that instrumentalists can join range in size from a few participants to very large ensembles, such as quartets, jazz bands, school bands, community bands, orchestras, drum and bugle corps, and marching bands. When taking a closer look at the intrinsic value of participating in a high school marching band, it can be noted that these experiences yield valuable character-building lessons for youth. Students learn about the importance of teamwork, shared responsibility, self-discipline and goal setting, time management and sharp observation skills. Behaviors can be strenuous and weather conditions can be unpleasant, yet perseverance makes the difference in what can be accomplished. Resilience is evident as band members bounce back from mistakes to achieve perfection. Great satisfaction is felt when band members are given recognition publicly, be it in the form of playing of tribute music and creation of “rowing, complete designs that change through marching in time with the music.

For those who learned how to play a musical instrument in their youth, there may be more benefits from those activities than just experiencing the pleasure of making music. Brenda Hanna-Pecky and Alison Vokonas, researchers at University of Texas Medical Center, studied the effects of music instruction in childhood on the cognitive stability of 70 healthy adults, ages 40-80. The participants were grouped according to their music-making experiences. Aside from the control group of non-musicians, the other participants in the study shared learning how to play a musical instrument around 10 years of age. The researchers discovered that the participants who played an instrument for at least 10 years performed significantly better on the battery of cognitive tests than the other participants in the study.¹³

The Positive Effects of Music Intervention Programs in Communities

The field of research has been expanding as scientists look for ways music can be used as an intervention tool. One particular area of interest is the impact of music education on the achievement gap between students from low-income families and those from affluent families. Dr. Nina Kraus, a neuroscientist and director of Northwestern University’s Auditory Neuroscience Laboratory in Evanston, Illinois, is facilitating long-term studies to find out what impact school and community-based music training has on the academic accomplishments of at-risk children. In 2014, she and her team of colleagues started conducting a randomized, controlled study of the long-term neurological benefits on children enrolled in The Harmony Project, which was founded by Margaret Martin in Los Angeles. Through this program that was started in 2001, students from low-income families who have not had any music education are enrolled in after-school weekly music classes and summer rehearsals that are led by professional musicians and held year-round. The success rate of this program is commendable. The Harmony Project now holds with over 2,000 students annually from low-income communities. Since 2008, more than 80% of the high school seniors enrolled in this project





Sculptural Collection

Six Instruments

- L:** Lilypad Cymbals
- C:** Contrabass Chimes
- A:** Aria
- P:** Pagoda Bells
- H:** Harp
- M:** Manta Ray

Our most sculptural instruments add an artistic flair to any outdoor space. A beautiful grouping of both resonated and non-resonated instruments, each instrument in this collection has upgraded steel posts offering a sophisticated look.

Mounting Options:

In-Ground
Surface Mount
See page 34 for
mounting options.

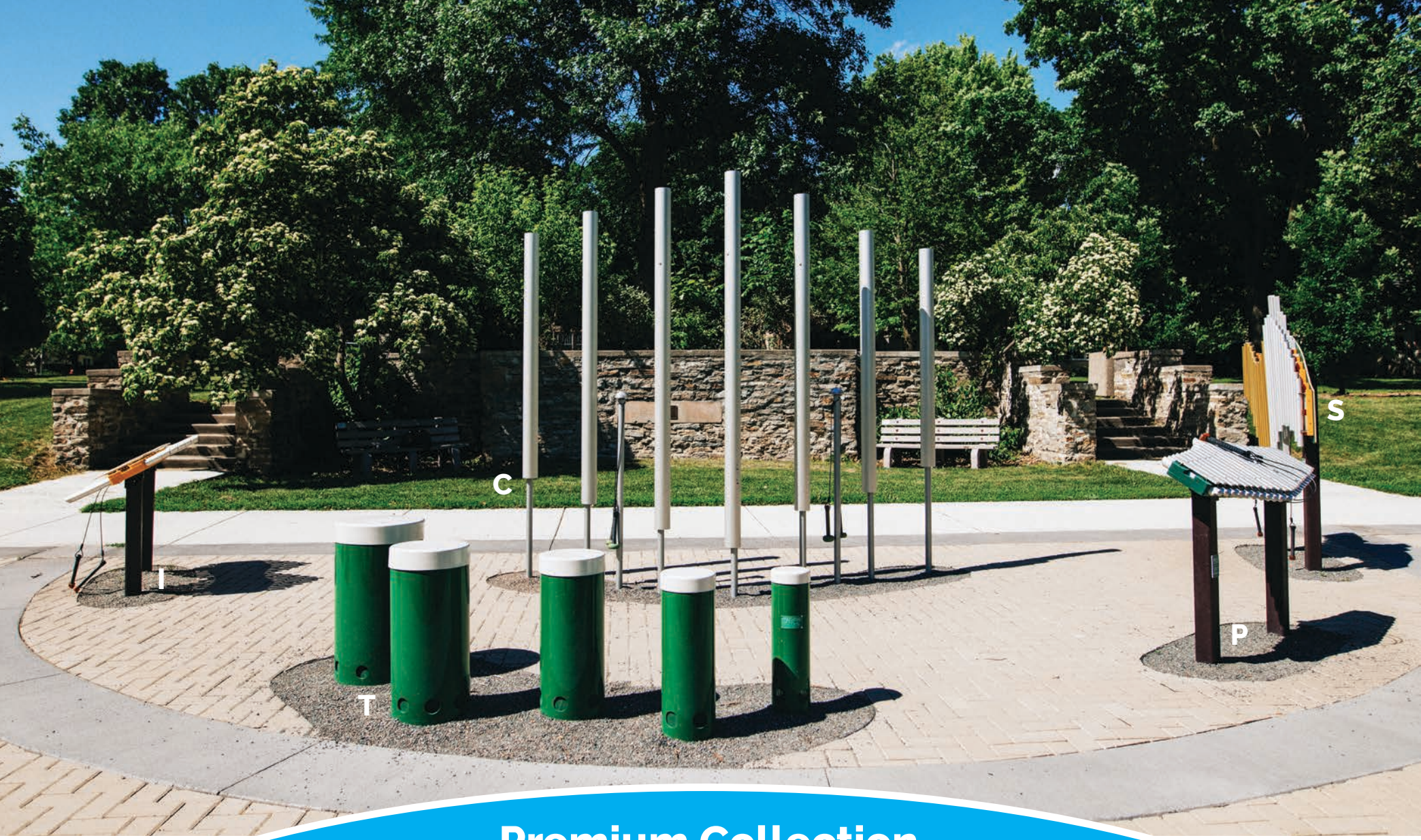

Premium Collection

Five Instruments

- I:** Imbarimba
- C:** Contrabass Chimes
- S:** Swirl
- P:** Pegasus
- T:** Tuned Drums

[4]

This collection provides all of our best selling instruments in one package. Experience a range of low tones to angelic chimes and the texture of both wooden and metal instruments. The Premium Collection offers the greatest variety of instruments for your investment.

Mounting Options:

- In-Ground
 - Surface Mount
- See page 34 for mounting options.



Deluxe Collection

Four Instruments

- Y:** Yantzee
- S:** Swirl
- T:** Tuned Drums
- I:** Imbarimba

The Deluxe Collection is a mixed quartet of instruments with a variety of soothing sounds. This smaller, more affordable group of instruments still offers a diverse sound scape and is just as much fun as the larger collections.

(UMBRELLA IN PHOTO NOT INCLUDED)

Mounting Options:

In-Ground
Surface Mount
See page 34 for
mounting options.



Starter Collection

Three Instruments

- Y:** Yantzee
- T:** Tuned Drums
- D:** Duet

The trio of instruments in the Starter Collection offers a robust sound profile that is easy on the budget. Featuring the Duet, an instrument with two unique sounds and two sets of mallets, this collection is a great way to introduce the joy of outdoor music in your community.

Mounting Options:

- In-Ground
 - Surface Mount
- See page 34 for mounting options.



Weenotes Collection

Three Instruments

- M:** Merry
- G:** Griffin
- P:** Piper

This is our most popular collection. A grouping of smaller sized instruments that have fewer keys, but the same high quality sound as our larger instruments. Great for kids and adults alike, this collection provides space efficiency.

Mounting Options:

- In-Ground
 - Surface Mount
- See page 34 for mounting options.



Flower Collection

Four Instruments

- ID:** Indigo
- O:** Orange
- Y:** Yellow
- T:** Turquoise

This enchanted garden collection includes four musical flowers with a range of 13 different notes, variations in height, and organic colors that create a harmonic chorus of sweet sounds. While each flower can be purchased separately, there are cost benefits when ordering the full bouquet.

Mounting Options:

- In-Ground
 - Surface Mount
- See page 34 for mounting options.



Flowers

Each Flower features a distinct musical chord, size, height, and color, and when the petals are struck they emit a rich, long-sustaining gong. The Flowers add both a sculptural and aesthetic design that invites users both young and old to create music in an outdoor environment. Each Flower is sold separately, or can be purchased at significant savings for all 4 pieces.

Mounting Options: In-Ground - Surface Mount - Portable Mount
See page 34 for mounting options.

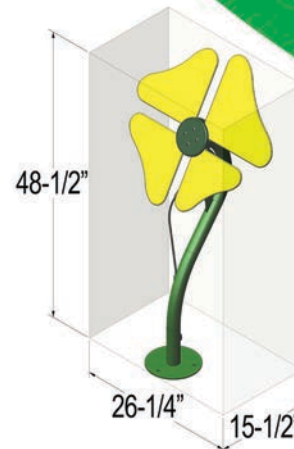

Style	Bell
# of notes	4
Material	Aluminum / Anodized
Sound	Bright / Sustaining
Resonated	No
Range	Alto / Soprano
Pentatonic	Yes
Key / Scale	Varies
Fully Assembled	Yes



Serenade

Serenade an audience with the ability to play songs using the color-coded chimes and songbook. Learn to play in 2 different ways - by color or by the annotated notes on the instrument and in the book. Read music without any prior knowledge and let the learning begin. Song book includes: Happy Birthday, Mary Had a Little Lamb, Twinkle Twinkle Little Star, Bingo, Row Row Row Your Boat, and Rock a Bye Baby.

Mounting Options: In-Ground - Surface Mount - Portable Mount
See page 34 for mounting options.

Style	Xylophone
# of notes	15
Material	Aluminum / Anodized
Sound	Bright / Sustaining
Resonated	Yes
Range	Alto / Soprano
Diatonic	Yes
Key / Scale	C - Major
Fully Assembled	Yes

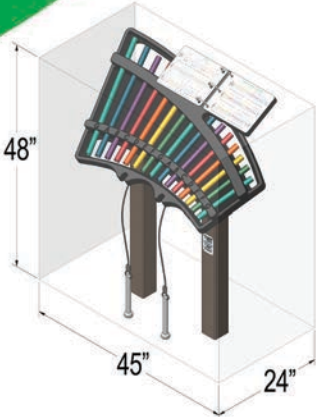

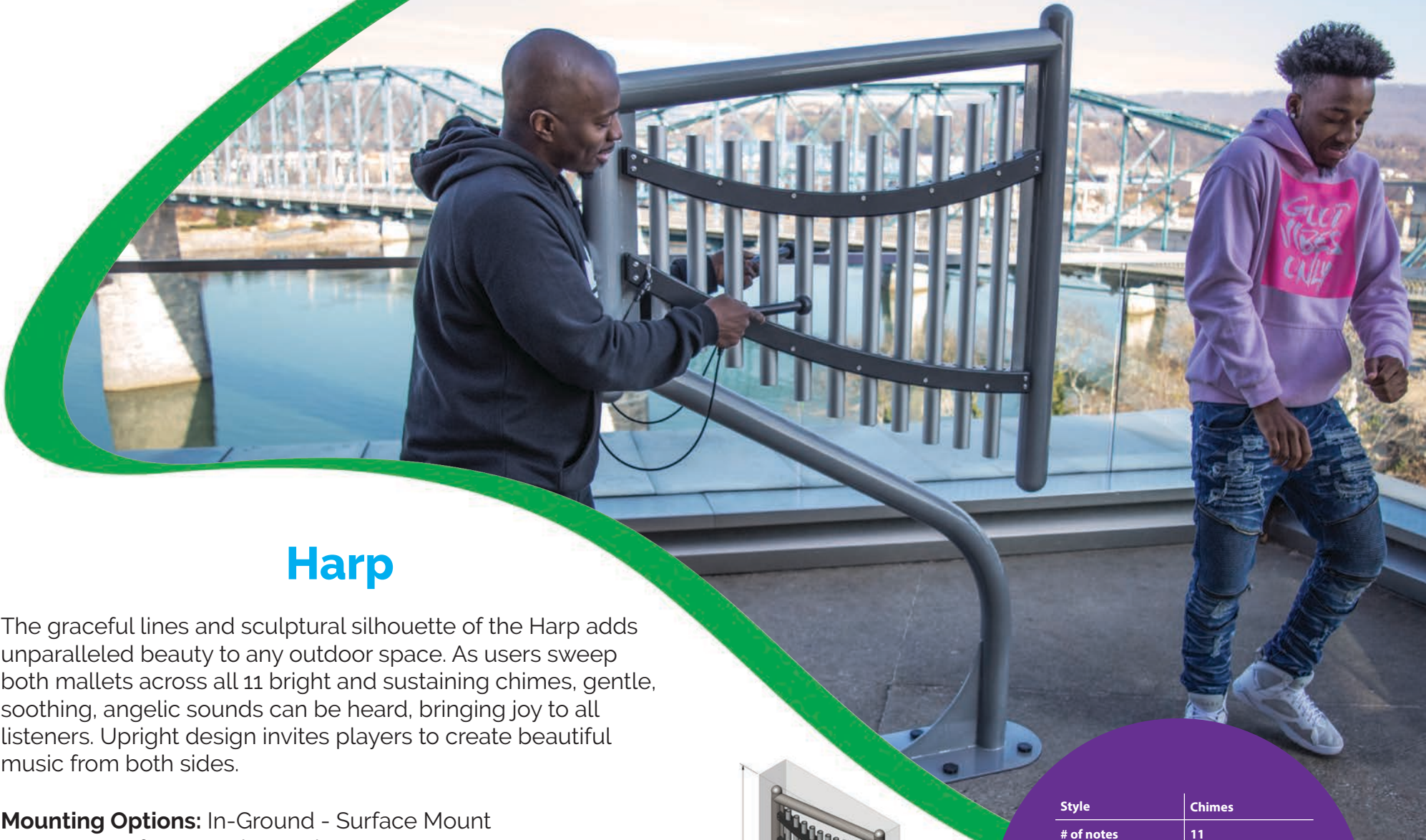

Harp

The graceful lines and sculptural silhouette of the Harp adds unparalleled beauty to any outdoor space. As users sweep both mallets across all 11 bright and sustaining chimes, gentle, soothing, angelic sounds can be heard, bringing joy to all listeners. Upright design invites players to create beautiful music from both sides.

Mounting Options: In-Ground - Surface Mount
See page 34 for mounting options.

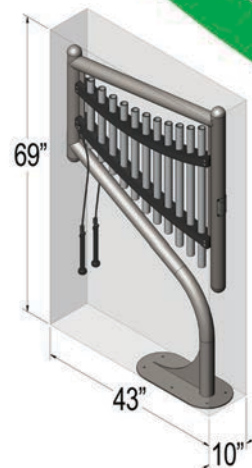

Style	Chimes
# of notes	11
Material	Aluminum / Anodized
Sound	Bright / Sustaining
Resonated	No
Range	Alto / Soprano
Pentatonic	Yes
Key / Scale	C Major
Fully Assembled	Yes



Tuned Drums

Bringing rhythmic, percussive sounds to the outdoors has never been easier with the Tuned Drums. Featuring a distinctive Afro-Cuban influence similar to Congo Drums, this set of five drums can be played by hand, creating deep resonating beats that inspire movement and dance. Available in two sizes - Adult or Toddler. Drums can be installed in any arrangement or layout, or can be purchased individually to create a unique set.

Mounting Options: In-Ground - Surface Mount - Portable Mount
See page 34 for mounting options.

Style	Drums
# of notes	5
Material	Molded Plastic
Sound	Percussive
Resonated	Yes
Range	Bass / Alto / Soprano
Pentatonic	Yes
Key / Scale	N/A
Fully Assembled	Yes

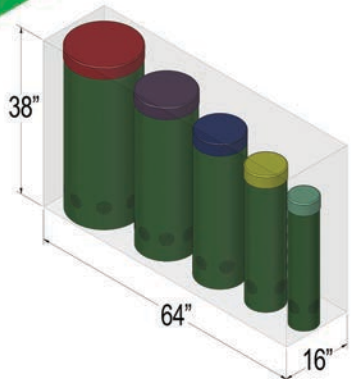



Lilypad Cymbals

Similar to their organic cousins, the Lilypad Cymbals invite users to hop around the multi-layered placement of 10 circular discs using 3 individual mallets as their guide. The bright, sustaining notes create a wave of pleasing sounds, inspiring dozens of note combinations. Up to 3 users can participate for even more fun.

Mounting Options: In-Ground - Surface Mount - Portable Mount
See page 34 for mounting options.

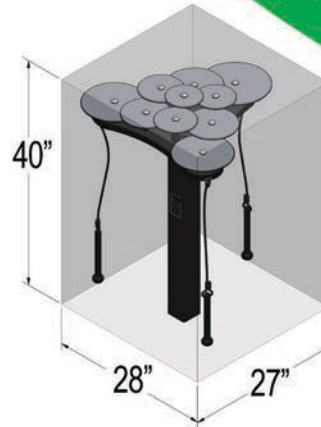

Style	Bells
# of notes	10
Material	Aluminum / Anodized
Sound	Bright / Sustaining
Resonated	No
Range	Alto / Soprano
Pentatonic	Yes
Key / Scale	C
Fully Assembled	Yes



Pegasus

The Pegasus spreads its wings in two keys, C Major and A Minor. A resonated metallophone made with anodized aluminum bars, the Pegasus creates bright and beautiful tones. This instrument resonates like a gong and has a sleek, classy style.

Mounting Options: In-Ground - Surface Mount - Portable Mount
See page 34 for mounting options.

Style	Xylophone
# of notes	23
Material	Aluminum / Anodized
Sound	Bright / Sustaining
Resonated	Yes
Range	Alto / Soprano
Pentatonic	Yes
Key / Scale	A & C
Fully Assembled	Yes

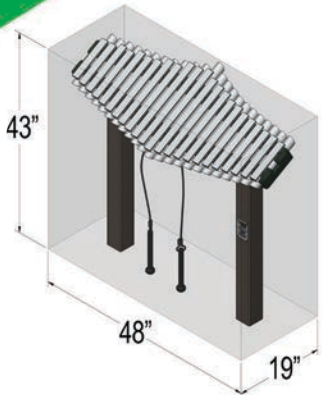



Imbarimba

The Imbarimba design combines elements of two African classic instruments, the marimba (a resonated xylophone) and the kalimba (a thumb piano). The coated fiberglass bars are entirely weatherproof, withstand hard use, and deliver the sound of a wooden instrument without the maintenance.

Mounting Options: In-Ground - Surface Mount - Portable Mount
See page 34 for mounting options.

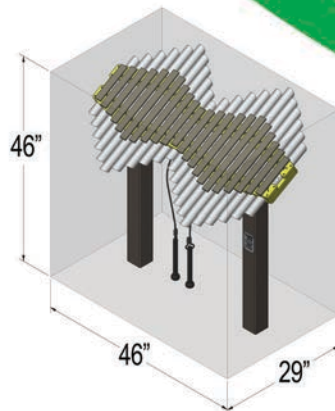

Style	Marimba
# of notes	22
Material	Fiberglass / Coated
Sound	Earthy / Percussive
Resonated	Yes
Range	Alto / Soprano
Pentatonic	Yes
Key / Scale	A & C
Fully Assembled	Yes



Contrabass Chimes

Stunning in both their towering appearance and low resonant sound, ranging in height from seven to nine feet, Contrabass Chimes can be installed in a variety of layouts including a horseshoe shape to experience a “surround sound” effect. Additional chimes may be purchased separately. The set comes with two mallet poles and four total mallets.

Mounting Options: In-Ground - Surface Mount
See page 34 for mounting options.

Style	Chimes
# of notes	7
Material	Aluminum / Anodized
Sound	Bass / Sustaining
Resonated	No
Range	Bass
Pentatonic	Yes
Key / Scale	C
Fully Assembled	Yes

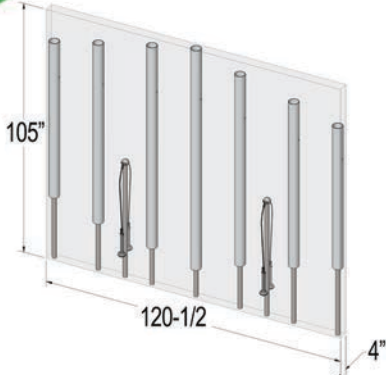



Manta Ray

The design and tonal qualities of the Manta Ray both undulate and ripple, mimicking the actual wingspan of a Manta Ray. Featuring two sides with four mallets, users can produce airy and tranquil sounds from this graceful, artistic instrument. Ideal for two people to play side-by-side.

Mounting Options: In-Ground - Surface Mount - Portable Mount
See page 34 for mounting options.

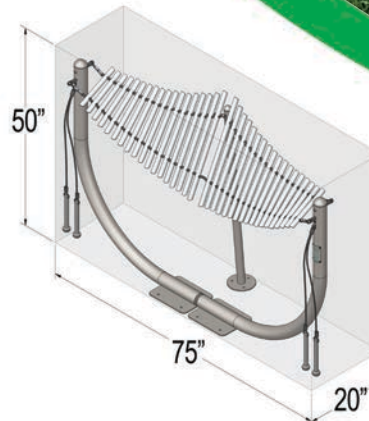

Style	Chimes
# of notes	36
Material	Aluminum / Anodized
Sound	Bass / Sustaining
Resonated	No
Range	Soprano
Diatonic	Yes
Key / Scale	C
Fully Assembled	Yes

Featured Harmony Park

A photograph of Harmony Park in Moab, Utah. The scene is dominated by a large, mature tree with a thick trunk and dense green foliage. In the foreground, a man in a dark long-sleeved shirt and khaki shorts stands with his back to the camera, playing a set of Freenotes. To his right, a young child in a red shirt is playing on a wooden structure with colorful cylindrical components. The park is lush with green grass and trees, creating a serene and natural environment.

Moab, Utah

Established in 1995, the first installation of Freenotes in Moab, Utah's Rotary Park, is still being played today. This park is consistently rated in the national rankings for best park/playground.





Yantzee

A foundational piece for any instrument grouping, the low notes of the Yantzee create a rich canvas of sound for the other melodic instruments to play over. An excellent accompaniment for all other Freenotes instruments.

Mounting Options: In-Ground - Surface Mount - Portable Mount
See page 34 for mounting options.

Style	Xylophone
# of notes	10
Material	Aluminum / Anodized
Sound	Bass / Sustaining
Resonated	Yes
Range	Bass
Pentatonic	Yes
Key / Scale	A
Fully Assembled	Yes

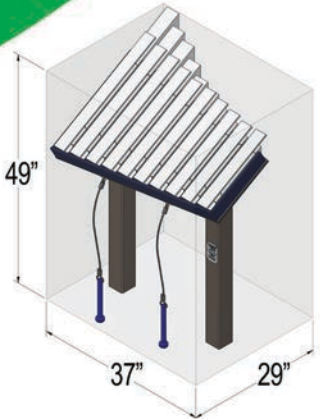



Pagoda Bells

Reminiscent of Asian architecture, the Pagoda Bells provide lush tones with sustaining duration, and provide a calming, aesthetic to gardens and outdoor settings. This classic, inspired design is both durable and maintenance free.

Mounting Options: In-Ground - Surface Mount - Portable Mount
See page 34 for mounting options.



Style	Bell
# of notes	8
Material	Stainless Steel
Sound	Bright / Sustaining
Resonated	No
Range	Alto / Soprano / Bass
Pentatonic	No
Key / Scale	No
Fully Assembled	Yes



Swirl

The stunning sculptural design exudes both beautiful sounds and visual art. One side of the Swirl plays the key of C and the other, the key of A Minor. The Swirl can also be wall mounted as a space saver, or to show off the floating musical notes on the back for a double-sided sculpture.

Mounting Options: In-Ground - Surface Mount
See page 34 for mounting options.

Style	Chimes
# of notes	26
Material	Aluminum / Anodized
Sound	Bright / Sustaining
Resonated	Yes
Range	Alto / Soprano
Pentatonic	Yes
Key / Scale	A & C
Fully Assembled	Yes

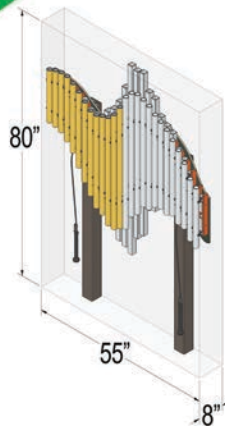



Duet

Enjoy both earthy and sustaining sounds with the Duet, featuring both a marimba and a xylophone in one instrument. With four mallets, the Duet invites 2 people to share an enhanced musical experience, as they elevate both rhythmic and chime intonations.

Mounting Options: In-Ground - Surface Mount - Portable Mount
See page 34 for mounting options.

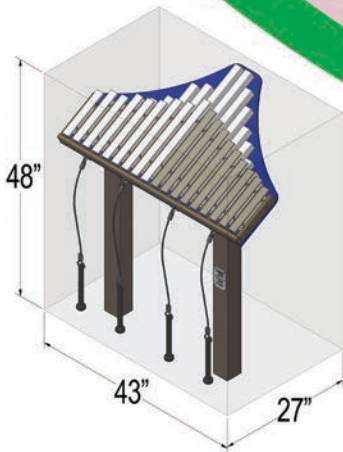

Style	Marimba / Xylophone
# of notes	18
Material	Fiberglass / Aluminum
Sound	Earthy / Sustaining
Resonated	Yes
Range	Alto / Soprano
Pentatonic	Yes
Key / Scale	A & C
Fully Assembled	Yes



Griffin

The Griffin produces warm, rich, full tones that resonate for up to 5 seconds, evoking the feel of finger painting with sound. As the mallet gently sweeps across the chimes, sound waves waft through the air similar to a harp, creating pleasing melodies that can be enjoyed by children and adults alike.

Mounting Options: In-Ground - Surface Mount - Portable Mount
See page 34 for mounting options.

Style	Chimes
# of notes	11
Material	Aluminum / Anodized
Sound	Bright / Sustaining
Resonated	Yes
Range	Alto / Soprano
Pentatonic	Yes
Key / Scale	N/A
Fully Assembled	Yes

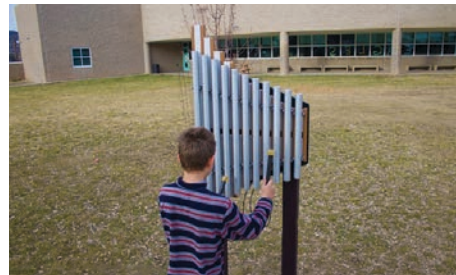
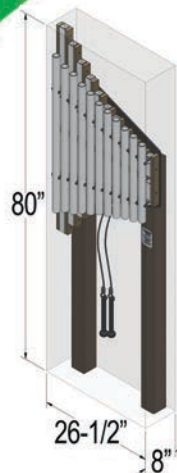



Cadence

Deep vibrant tones ring clear on this tenor marimba. Wide, coated fiberglass keys play sounds similar to a wooden instrument and reminiscent of the islands. With a recycled, reinforced plastic resonated base this instrument is a solid favorite. Also a favorite with musicians, this instrument inspires long improvisational play and tons of fun.

Mounting Options: In-Ground - Surface Mount - Portable Mount
See page 34 for mounting options.

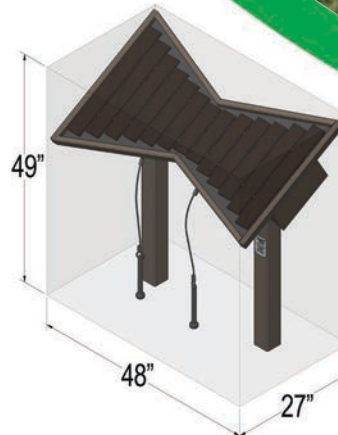

Style	Marimba
# of notes	13
Material	Coated Fiberglass
Sound	Earthy / Percussive
Resonated	Yes
Range	Alto / Bass
Pentatonic	Yes
Key / Scale	C
Fully Assembled	Yes



Merry

This bright-sounding instrument makes a melody with its lyrical voice. It is a smaller version of the Pegasus seen on page 14. A xylophone companion to Piper's marimba, played together they are quite the pair. One of the most pleasant sounding instruments and a best-seller.

Mounting Options: In-Ground - Surface Mount - Portable Mount
See page 34 for mounting options.

Style	Xylophone
# of notes	11
Material	Aluminum / Anodized
Sound	Bright / Sustaining
Resonated	Yes
Range	Alto / Soprano
Pentatonic	Yes
Key / Scale	C
Fully Assembled	Yes

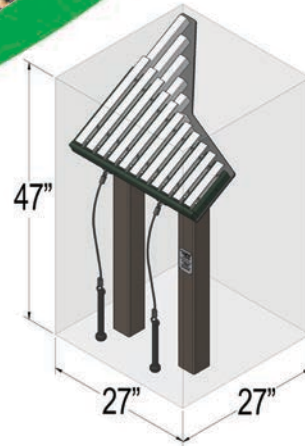



Piper

A great instrument to play improvisational rhythms, also an instrument with sounds reminiscent of the islands with higher tones than the Cadence. This instrument features fiberglass bars providing a contrast in tone to its sister, the Merry. A perfect pair that will provide delightfully full sounds of a small ensemble when played together.

Mounting Options: In-Ground - Surface Mount - Portable Mount
See page 34 for mounting options.

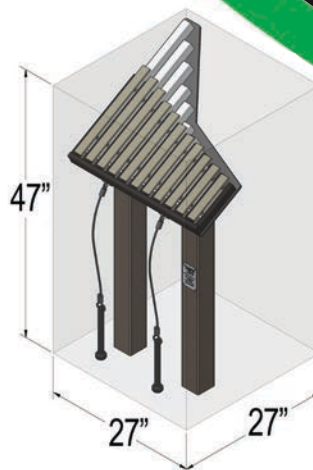

Style	Marimba
# of notes	11
Material	Fiberglass Coated
Sound	Earthy / Percussive
Resonated	Yes
Range	Alto / Soprano
Pentatonic	Yes
Key / Scale	C
Fully Assembled	Yes



Melody

The Melody has a beautiful twinkly sound with 9 notes in a small but elegant design. As one of our smaller instruments, it can be paired with the Rhythm for a space-saving design. This bright color hints of spring no matter what time of year it is played and enjoyed.

Mounting Options: In-Ground - Surface Mount - Portable Mount
See page 34 for mounting options.

Style	Xylophone
# of notes	9
Material	Aluminum / Anodized
Sound	Bright / Sustaining
Resonated	Yes
Range	Alto / Soprano
Pentatonic	Yes
Key / Scale	C
Fully Assembled	Yes

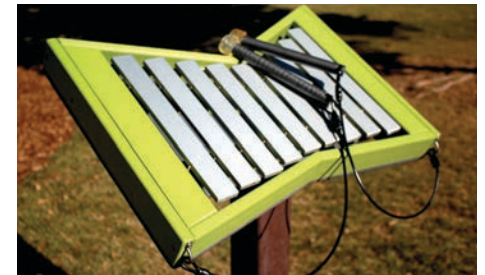



Rhythm

The fiberglass bars on this instrument inspire rhythm and dance. It is a space-saving design providing the African sounds of a wooden instrument without the maintenance challenges. Rhythm is a natural sounding instrument in a beautiful natural color and a percussive cousin to the Melody.

Mounting Options: In-Ground - Surface Mount - Portable Mount
See page 34 for mounting options.



Style	Marimba
# of notes	9
Material	Fiberglass Coated
Sound	Earthy / Percussive
Resonated	Yes
Range	Alto / Soprano
Pentatonic	Yes
Key / Scale	C
Fully Assembled	Yes



Aria

The sleek, yet graceful Aria emits sounds like a delicate breath of fresh air. Lighter in sound volume, it is a great choice for environments with a lower volume requirement. The steel powder coated body is incredibly strong while the open design allows the Aria to naturally blend into outdoor landscapes.

Mounting Options: In-Ground - Surface Mount - Portable Mount
See page 34 for mounting options.

Style	Xylophone
# of notes	9
Material	Aluminum / Anodized
Sound	Bright / Sustaining
Resonated	No
Range	Alto / Soprano
Pentatonic	Yes
Key / Scale	C
Fully Assembled	Yes

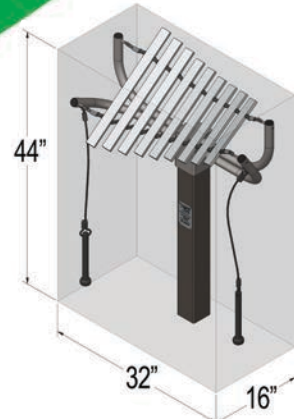

Mallet Variations

Every instrument comes with mallets that are specifically designed to enhance the playability and sound for your delight. We also offer a **FREE EXTRA SET OF MALLETS** for every instrument (upon request). With a unibody system and thicker cables these mallets are stronger than ever, yet easily replaceable if necessary.



Mallet Holder

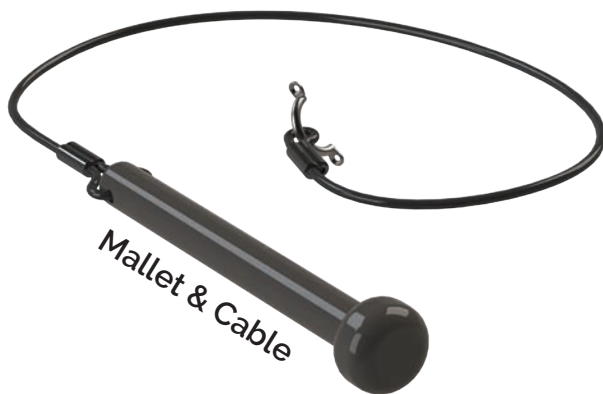

GREY / 90 DUROMETER

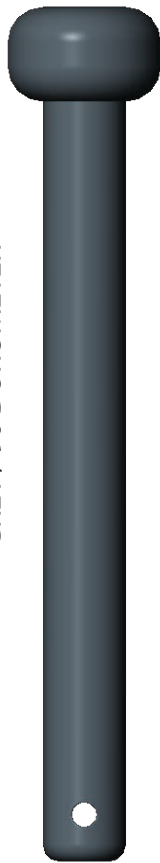

BLUE / 70 DUROMETER



BLACK / 80 DUROMETER



GREY / 70 DUROMETER
(USED ON CONTRABASS CHIMES)



(INCLUSIVE) BLACK / 80 DUROMETER

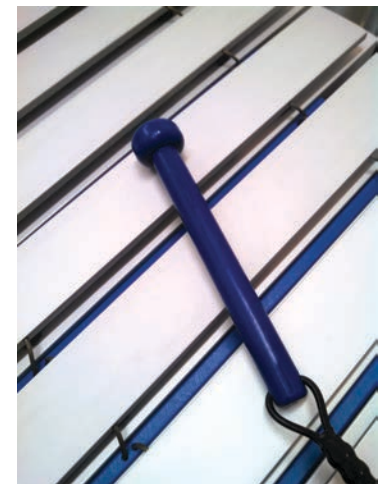
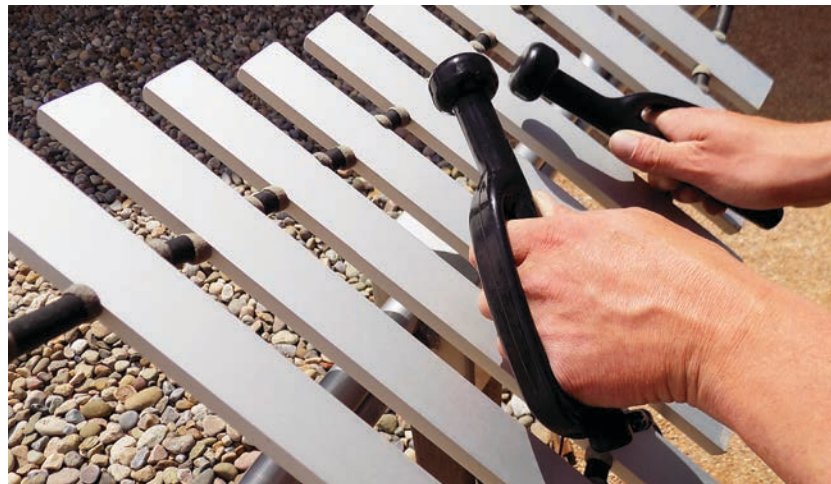

Music Term Definitions

- Percussive** - An instrument that emits sound through singular or repetitive strikes.
- Bass** - Deep, low pitch sounds, from the lower octaves of the musical range.
- Alto** - The second highest part of the musical range.
- Soprano** - The highest part of the musical range.
- Pentatonic** - Pentatonic harmonies are gentle and soothing, a five note music scale. The nature of the scale means it is impossible to make any real harmonic mistakes.
- Diatonic** - Freenotes diatonic instruments use the C major scale better known as the white notes on the piano.
- Sustaining** - To support something or keep it going. Sustaining instruments have tones that sound for several seconds.
- Resonated** - Freenotes resonated instruments use accoustical (not electronic) air cavities to produce a fuller, reverberating sound.

"I would teach children music, physics, and philosophy; but most importantly music, for the patterns in music and all the arts are the keys to learning." ~ Plato

Sound Quality & Pitch Range

Instrument	Percussive	Sustaining
Aria (Page 30)		●
Cadence (Page 25)	●	
Contrabass Chimes (Page 16)		●
Duet (Page 23)	●	●
Flowers (Page 9)		●
Griffin (Page 24)		●
Harp (Page 11)	●	●
Imbarimba (Page 15)	●	
Lilypad Cymbals (Page 13)	●	
Manta Ray (Page 17)		●
Melody (Page 28)		●
Merry (Page 26)		●
Pagoda Bells (Page 21)	●	●
Pegasus (Page 14)		●
Piper (Page 27)	●	
Rhythm (Page 29)	●	
Serenade (Page 10)		●
Swirl (Page 22)		●
Tuned Drums (Page 12)	●	
Yantzee (Page 20)		●

Bass	Alto	Soprano
	●	●
●	●	
●		
	●	●
	●	●
	●	●
	●	●
	●	●
	●	●
	●	●
	●	●
	●	●
●	●	●
	●	●
	●	●
	●	●
●	●	●
●		

Chimes	Xylophone	Marimba	Bells
	●		
		●	
●		●	
	●		●
●			
●		●	
			●
	●		
	●		
			●
	●		
		●	
●		●	
●			
	●		

Mounting Options & Part Numbers

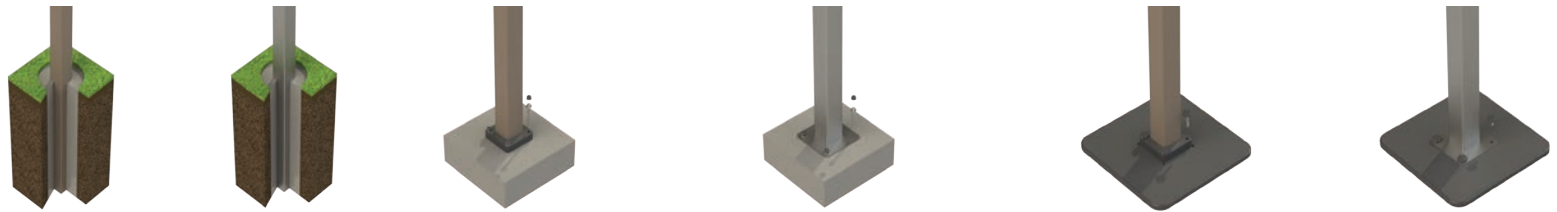

	In Ground - Recycled Post	In Ground - Steel Post	Surface Mount - Recycled Post	Surface Mount - Steel Post	Portable Mount - Recycled Post	Portable Mount - Steel Post
ARIA	ARIA-IG-REC-KIT	ARIA-IG-STL-KIT	ARIA-SM-REC-KIT	ARIA-SM-STL-KIT	ARIA-PM-REC-KIT	ARIA-PM-STL-KIT
CADENCE	CADE-IG-REC-KIT	CADE-IG-STL-KIT	CADE-SM-REC-KIT	CADE-SM-STL-KIT	CADE-PM-REC-KIT	CADE-PM-STL-KIT
CONTRABASS CHIMES		CCH-IG-KIT		CCH-SM-KIT		
DUET	DUET-IG-REC-KIT	DUET-IG-STL-KIT	DUET-SM-REC-KIT	DUET-SM-STL-KIT	DUET-PM-REC-KIT	DUET-PM-STL-KIT
GRIFFIN	GRIF-IG-REC-KIT	GRIF-IG-STL-KIT	GRIF-SM-REC-KIT	GRIF-SM-STL-KIT	GRIF-PM-REC-KIT	GRIF-PM-STL-KIT
HARP				HRP-IG-KIT (Also Serves As In Ground)		
IMBARIMBA	IMBA-IG-REC-KIT	IMBA-IG-STL-KIT	IMBA-SM-REC-KIT	IMBA-SM-STL-KIT	IMBAPM-REC-KIT	IMBA-PM-STL-KIT
LILYPAD CYMBALS	LPAD-IG-REC-KIT	LPAD-IG-STL-KIT	LPAD-SM-REC-KIT	LPAD-SM-STL-KIT	LPAD-PM-REC-KIT	LPAD-PM-STL-KIT
MANTA RAY				MRAY-IG-KIT (Also Serves As In Ground)		MRAY-PM-KIT
MELODY	MELD-IG-REC-KIT	MELD-IG-STL-KIT	MELD-SM-REC-KIT	MELD-SM-STL-KIT	MELD-PM-REC-KIT	MELD-PM-STL-KIT
MERRY	MERY-IG-REC-KIT	MERY-IG-STL-KIT	MERY-SM-REC-KIT	MERY-SM-STL-KIT	MERY-PM-REC-KIT	MERY-PM-STL-KIT
PAGODA BELLS	PBEL-IG-REC-KIT	PBEL-IG-STL-KIT	PBEL-SM-REC-KIT	PBEL-SM-STL-KIT	PBEL-PM-REC-KIT	PBEL-PM-STL-KIT
PEGASUS	PEG-IG-REC-KIT	PEG-IG-STL-KIT	PEG-SM-REC-KIT	PEG-SM-STL-KIT	PEG-PM-REC-KIT	PEG-PM-STL-KIT
PIPER	PIPR-IG-REC-KIT	PIPR-IG-STL-KIT	PIPR-SM-REC-KIT	PIPR-SM-STL-KIT	PIPR-PM-REC-KIT	PIPR-PM-STL-KIT
RHYTHM	RHYT-IG-REC-KIT	RHYT-IG-STL-KIT	RHYT-SM-REC-KIT	RHYT-SM-STL-KIT	RHYT-PM-REC-KIT	RHYT-PM-STL-KIT
SERENADE	SRND-IG-REC-KIT	SRND-IG-STL-KIT	SRND-SM-REC-KIT	SRND-SM-STL-KIT	SRND-PM-REC-KIT	SRND-PM-STL-KIT
SWIRL	SWRL-IG-REC-KIT	SWRL-IG-STL-KIT		SWRL-SM-STL-KIT		
YANTZEE	YANZ-IG-REC-KIT	YANZ-IG-STL-KIT	YANZ-SM-REC-KIT	YANZ-SM-STL-KIT	YANZ-PM-REC-KIT	YANZ-PM-STL-KIT



	In Ground	Surface Mount	Portable Mount
TUNED DRUMS – NORMAL HEIGHT	TD-IG-N-KIT	TD-SM-N-KIT	TD-PM-N-KIT
TUNED DRUMS – TODDLER HEIGHT	TD-IG-T-KIT	TD-SM-T-KIT	TD-PM-T-KIT

	Surface Mount - Steel Post	Portable Mount - Steel Post
FLOWER – TURQUOISE	FWR-T-IG-KIT (Also Serves As In Ground)	FWR-T-PM-KIT
FLOWER – ORANGE	FWR-O-IG-KIT (Also Serves As In Ground)	FWR-O-PM-KIT
FLOWER – INDIGO	FWR-I-IG-KIT (Also Serves As In Ground)	FWR-I-PM-KIT
FLOWER – YELLOW	FWR-Y-IG-KIT (Also Serves As In Ground)	FWR-Y-PM-KIT



	Rainbow	Natural	Taupe	Moss
TUNED DRUMS – CAP CHOICES	TD-CAP-RB	TD-CAP-N	TD-CAP-T	TD-CAP-M

The Story



Freenotes instruments were originally developed by Grammy Award-winning musician Richard Cooke in 1995. The idea came as a solution to the impediments of learning to play a traditional instrument and needing to read music. His experience of learning to play the flute in an improv style without taking any lessons or reading music was so profound, he wanted to teach others how they might experience this freedom of playing music instinctively. So many barriers were in the way that he decided to create instruments to make it possible.

First, was the immense hurdle of wrong notes. Everyone who has tried to play knows the anguish of having the music stop because a note goes wrong. He decided to take them all out. Then there were all those intricate finger movements that take years to master, they had to go too. He started to build xylophones that had no sharps or flats and were

played not with the tiny muscles of the fingers, but with the large coordinated muscles of the arms and hands. The ergonomics of the instruments is an important factor.

"He thought about putting instruments in the public spaces so anyone could play whenever they wished."

He made the tones sound so beautiful that everyone who started to play wouldn't want to stop. He also realized that not everyone has the money to buy an instrument, let alone several so that they can play with their friends and family, which is when the music really comes alive. He wanted to find a way to allow everyone who wanted to play music to be able to do so. He thought about putting instruments in the public spaces so anyone could play whenever they wished. And that's how he started to make music parks over twenty years ago, so we could all share in the joy and freedom of playing music successfully.

In June 2016 Richard did a Ted Talk about his story at TEDx Mile High. Hear the story from the man himself by visiting our website: www.freenotesharmony.com



- Perfectly Tuned
- Multi-Generational
- No "Wrong" Notes
- No Power Required
- Low Maintenance
- Fully Assembled
- Made In The U.S.A.

GET IN TOUCH HERE



Durango, Colorado, CO 81303



(833) 262-1569
(970) 375-7825



info@freenotesharmoniypark.com



www.freenotesharmoniypark.com

A **PLAYCORE** Company

Cross Over Into
Music Land